



TECHNICAL DATA

Cycle times (*)	120 / 240 / 360 sec. and special cycles
Water consumption	4.5 l/rack
Tank capacity	80 l
Tank heating	3.3 kW
Power supply	400 / 50 / 3N
Booster loading	
Standard	12.3 kW
Reduced	6.15 kW
Total loading	
Standard	15.6 kW 3 x 35 A
Reduced	12.6 kW 3 x 20 A
Wash pump	2.7 kW
Rack size	600 x 760 mm
Loading height	860 mm
Noise level	65 dB (A)
Weight (gross / net)	230 / 215 kg

PRODUCT ADVANTAGES

- **POWER-PLUS Washing:** high-pressure washing to wash heavily soiled wash items
- **ROTOR-X Wash System:** separate rotating upper and lower 4-spoke wash arms deliver dynamic wash power
- **PROOF Strainer Control:** prevents operation without tank strainer
- **SMARTRONIC Single-button Control:** colour coded status indication and remaining time indicator
- **Machine height 2-in-1:** machine height can be reduced by up to 217 mm with the door open – for use in spaces with low ceilings
- **Permanent wash programme:** due to a longer cycle time even heavily soiled wash items are getting perfectly clean
- **VAPOSTOP Door System (optional):** prevents vapour to escape from machine when door is opened
- The optional **E-SAVE Drain Heat Recovery** transfers heat from hot drain water to the fresh-water supply, reducing boiler power consumption and saving up to 5.2 kW/h
- **GENIUS-X² Fine Filter System:** advanced filter system with pre-wash function reduces detergent consumption up to 35%
- **Loading height L:** above-average loading height of 860 mm
- The optional **exhaust heat recovery** with integrated Door System VAPOSTOP uses steam to heat fresh feed water and reduces the amount of power needed to reach the final rinse temperature, saving up to 3.1 kW/h
- **Hygiene Programme:** for removal of calcium carbonate and other deposits from wash chamber

*Thermostop guarantees required temperatures with cold water connection, the actual cycle times extend accordingly. For machine protection the water hardness should not exceed 3°dH, if higher we recommend using an integrated water softener or an external water softener of the product line HYDROLINE PROTECT.

CONNECTIONS

① Drain hose	2,000 mm ID20 / OD25
② Supply hose	2,000 mm R 3/4"
Flow pressure	0.5 (0.8 with softener) - 10 bar
Max. supply water temperature	60 °C
Required flow rate	5 l/min
③ Power cord	1.800 mm
Supply hose for	
④ Detergent	2.500 mm
⑤ Rinse aid	2.500 mm

DIMENSIONAL DRAWING

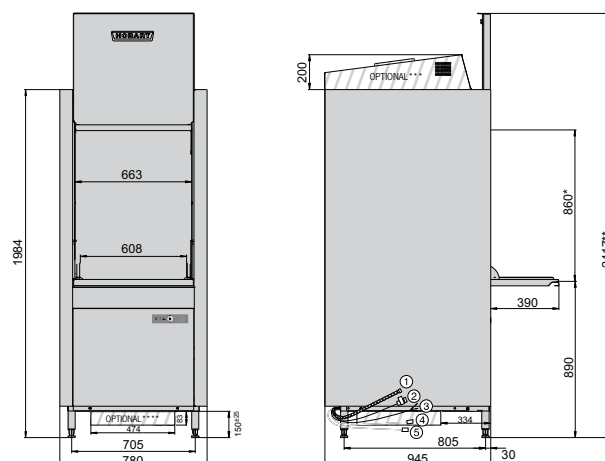

- * Loading height can be reduced to 650 mm
- ** Height can be reduced to 2,200 mm with the door open
- *** With exhaust heat recovery
- **** With heat recovery

